

CX LINE

Exploration drilling equipment
Équipements d'exploration minière



COMACCHIO

DRILLING HI-TECH

CRAWLER AND TRUCK MOUNTED DRILLING RIGS DESIGNED FOR THE MINING INDUSTRY MACHINES DE FORAGE SUR CHENILLES ET SUR CAMION CONÇUES POUR L'INDUSTRIE MINIERE

The CX line includes a range of multipurpose crawler and truck mounted drilling rigs designed and built for the mining industry. Bristling with technology and capability, these rigs are configured to meet the very stringent safety requirements of the mining industry, including an array of hands-free rod handling systems, developed by Comacchio to eliminate the hazards associated with manual handling and increase operational efficiency. The CX line rigs can be configured to perform diamond core drilling to great depths as well as reverse circulation rotary drilling, air core and grade control.

La ligne CX propose une gamme complète de machines de forage sur chenilles et sur camion conçues et construites pour l'industrie minière. Dotées de dispositifs à l'avant-garde de la technologie actuelle, ces foreuses sont configurées pour répondre aux exigences de sécurité très strictes de l'industrie minière, y compris une gamme de systèmes de manipulation de tiges, développés par Comacchio pour afin d'éliminer les risques associés à la manipulation manuelle et d'augmenter l'efficacité opérationnelle. Les machines de la ligne CX peuvent être configurées pour effectuer les carottages au diamant à grandes profondeurs, et aussi pour le forage par circulation inverse, en Air Core (AC) et le contrôle de la teneur de grade (Grade Control).

DD Diamond Core Drilling
Forage par carottage au diamant

RC Reverse Circulation
Forage par circulation inverse

GC Grade Control
Contrôle de la teneur de grade

INDICATIVE DRILLING CAPACITY

CAPACITÉ DE FORAGE INDICATIVE

* FRICTION %		CX 1010	CX 1515	CX 1520	CX 2020	CX 2030	CX 2520	CXT 10	CXT 15	CXT 20	CXT 30	
DD	BQ	0*	1.400 m 4,593 ft	2.400 m 7,874 ft	3.000 m 9,843 ft	3.000 m 9,843 ft	3.000 m 9,843 ft	---	1.400 m 4,593 ft	2.400 m 7,874 ft	3.000 m 9,843 ft	3.000 m 9,843 ft
		15*	1.200 m 3,937 ft	2.050 m 6,726 ft	2.700 m 8,858 ft	2.700 m 8,858 ft	3.000 m 9,843 ft	---	1.200 m 3,937 ft	2.050 m 6,726 ft	2.700 m 8,858 ft	3.000 m 9,843 ft
		30*	1.000 m 3,281 ft	1.750 m 5,741 ft	2.400 m 7,874 ft	2.400 m 7,874 ft	3.000 m 9,843 ft	---	1.000 m 3,281 ft	1.750 m 5,741 ft	2.400 m 7,874 ft	3.000 m 9,843 ft
	NQ	0*	1.100 m 3,601 ft	1.850 m 6,070 ft	2.500 m 8,202 ft	2.500 m 8,202 ft	3.500 m 11,483 ft	---	1.100 m 3,601 ft	1.850 m 6,070 ft	2.500 m 8,202 ft	3.500 m 11,483 ft
		15*	950 m 3,117 ft	1.600 m 5,249 ft	2.200 m 7,218 ft	2.200 m 7,218 ft	3.500 m 11,483 ft	---	950 m 3,117 ft	1.600 m 5,249 ft	2.200 m 7,218 ft	3.500 m 11,483 ft
		30*	800 m 2,625 ft	1.400 m 4,593 ft	1.900 m 6,234 ft	1.900 m 6,234 ft	2.800 m 9,186 ft	---	800 m 2,625 ft	1.400 m 4,593 ft	1.900 m 6,234 ft	2.800 m 9,186 ft
	HQ	0*	750 m 2,461 ft	1.250 m 4,101 ft	1.700 m 5,577 ft	1.700 m 5,577 ft	2.550 m 8,366 ft	---	750 m 2,461 ft	1.250 m 4,101 ft	1.700 m 5,577 ft	2.550 m 8,366 ft
		15*	650 m 2,133 ft	1.100 m 3,609 ft	1.500 m 4,921 ft	1.500 m 4,921 ft	2.300 m 7,546 ft	---	650 m 2,133 ft	1.100 m 3,609 ft	1.500 m 4,921 ft	2.300 m 7,546 ft
		30*	550 m 1,804 ft	950 m 3,117 ft	1.300 m 4,265 ft	1.300 m 4,265 ft	2.000 m 6,562 ft	---	550 m 1,804 ft	950 m 3,117 ft	1.300 m 4,265 ft	2.000 m 6,562 ft
	PQ	0*	550 m 1,804 ft	900 m 2,953 ft	1.200 m 3,937 ft	1.200 m 3,937 ft	1.850 m 6,070 ft	---	550 m 1,804 ft	900 m 2,953 ft	1.200 m 3,937 ft	1.850 m 6,070 ft
		15*	500 m 1,640 ft	800 m 2,625 ft	1.050 m 3,445 ft	1.050 m 3,445 ft	1.600 m 5,249 ft	---	500 m 1,640 ft	800 m 2,625 ft	1.050 m 3,445 ft	1.600 m 5,249 ft
		30*	400 m 1,312 ft	650 m 2,133 ft	900 m 2,953 ft	900 m 2,953 ft	1.400 m 4,593 ft	---	400 m 1,312 ft	650 m 2,133 ft	900 m 2,953 ft	1.400 m 4,593 ft
RC/GC	4" 1/2	0*	270 m 886 ft	400 m 1,312 ft	550 m 1,804 ft	550 m 1,804 ft	800 m 2,625 ft	550 m 1,804 ft	270 m 886 ft	400 m 1,312 ft	550 m 1,804 ft	800 m 2,625 ft
		15*	250 m 820 ft	350 m 1,148 ft	500 m 1,640 ft	500 m 1,640 ft	700 m 2,297 ft	500 m 1,640 ft	250 m 820 ft	350 m 1,148 ft	500 m 1,640 ft	700 m 2,297 ft
		30*	200 m 656 ft	280 m 919 ft	400 m 1,312 ft	400 m 1,312 ft	550 m 1,804 ft	400 m 1,312 ft	200 m 656 ft	280 m 919 ft	400 m 1,312 ft	550 m 1,804 ft

Drill rods depth rating must be verified with the manufacturer as BQ capacity is shown for comparison purposes only. The data on the table are indicative, calculated on vertical holes, which are variable and subjected to soil conditions, in hole-tools and flushing method.

La profondeur de forage doit être vérifiée avec le fabricant car la capacité BQ est indiquée à des fins de comparaison uniquement. Les données du tableau sont indicatives, calculées sur des trous verticaux, qui sont variables en fonction des conditions du sol, des outils de forage et des fluides de forage.

CX 1010

CX 1515

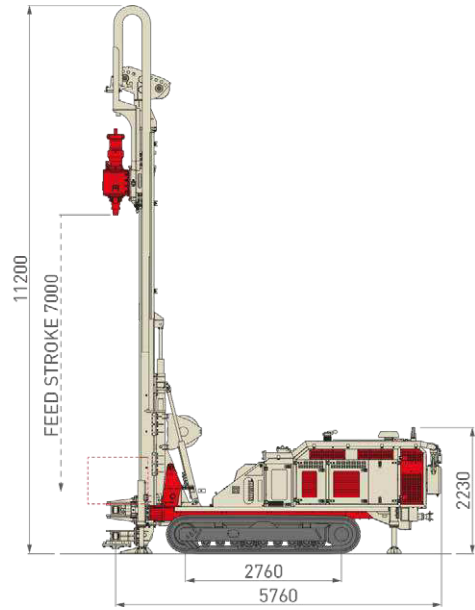
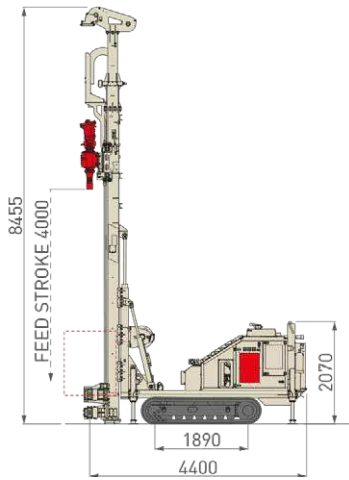

			m.s.	i.s.		
Engine Power <i>Puissance Moteur</i>	115 - 119	154 - 160	kW	HP	126 - 160	169 - 214
Emission Level <i>Norme d'Émissions</i>	<i>Step 3A/Tier 3 - Step 5 / Tier 4f (HT Line)</i>		-		<i>Step 3A/Tier 3 - Step 5 / Tier 4f (HT Line)</i>	
Feed Stroke <i>Course Utile</i>	4.000	13' 1"	mm	ft-in	4.000 - 7.000	13' 1" - 22' 12"
Feed Force <i>Force de Poussée</i>	6.500	14,612	daN	lbs	7.000	15,736
Retract Force <i>Force de Traction</i>	9.500	21,356	daN	lbs	15.000	33,721
Weight <i>Poids</i>	9.500 - 11.500	21,000 - 25,400	kg	lbs	15.000 - 17.000	33.000 - 37.500

	DD	RC	m.s.	i.s.	DD	RC
Rotary Torque Range <i>Couple Rotative</i>	2.300 - 8.350 1,696 - 6,159	11.000 - 13.000 8,113 - 9,588	Nm	lb*ft	5.365 - 13.600 3,957 - 10,031	11.000 - 13.600 8,113 - 10,031
Rotary Speed Range <i>Vitesse Rotative</i>	980 - 1.500	220 - 290	rpm		900 - 1.250	220 - 290
Clamp Range <i>Diam. Tige min/max</i>	55 - 124 2" 3/16 - 4" 7/8	45 - 320 1" 3/4 - 12" 5/8	mm	in	55 - 124 2" 3/16 - 4" 7/8	45 - 360 1" 3/4 - 14" 3/16
Fluid Circulation Pump <i>Pompe de Circulation de Fluide</i>	200 52.8	-	l/min.	gal/min.	200 52.8	-
Wire-line winch <i>Treuil Wire-line</i>	1.250 4,101	-	m	ft	1.800 5,905	-





CX 1520

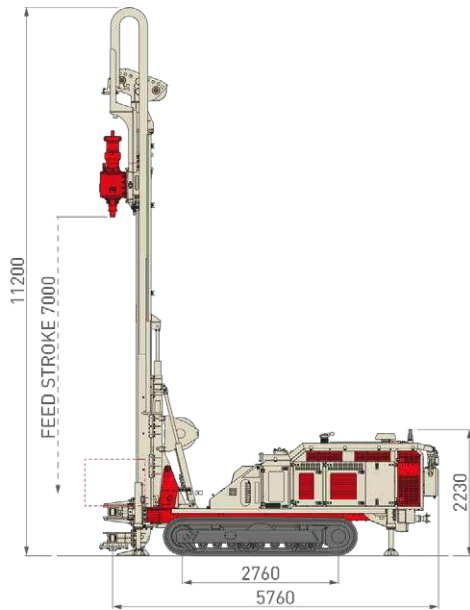

CX 2020

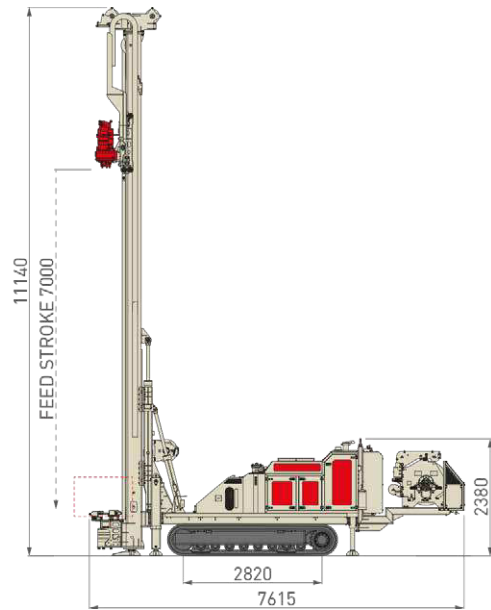

m.s. i.s.

Engine Power <i>Puissance Moteur</i>	126 - 160	169 - 214	kW	HP	188 - 245	255 - 333
Emission Level <i>Norme d'Émissions</i>	<i>Step 3A/Tier 3 - Step 5 / Tier 4f (HT Line)</i>		-			
Feed Stroke <i>Course Utile</i>	4.000 - 7.000	13' 1" - 22' 12"	mm	ft-in	4.500 - 7.000	14' 9" - 22' 12"
Feed Force <i>Force de Poussée</i>	12.000	26,977	daN	lbs	12.000	26,977
Retract Force <i>Force de Traction</i>	20.000	44,961	daN	lbs	20.000	44,961
Weight <i>Poids</i>	16.000 - 18.000	35,300 - 39,700	kg	lbs	19.000 - 22.000	41,900 - 48,500

DD

RC

m.s. i.s.

DD

RC

Rotary Torque Range <i>Couple Rotative</i>	5.365 - 13.600 3,957 - 10,031	11.000 - 13.600 8,113 - 10,031	Nm	lb*ft	5.365 - 13.600 3,957 - 10,031	13.600 - 27.000 10,301 - 19,914
Rotary Speed Range <i>Vitesse Rotative</i>	900 - 1.250	220 - 290	rpm		900 - 1.250	110 - 290
Clamp Range <i>Diam. Tige min/max</i>	55 - 124 2" 3/16 - 4" 7/8	45 - 360 1" 3/4 - 14" 3/16	mm	in	55 - 124 2" 3/16 - 4" 7/8	45 - 360 1" 3/4 - 14" 3/16
Fluid Circulation Pump <i>Pompe de Circulation de Fluide</i>	200 52.8	-	l/min.	gal/min.	200 52.8	-
Wire-line winch <i>Treuil Wire-line</i>	1.800 5,905	-	mm	ft	2.600 8,530	-



CX 2030

CX 2520

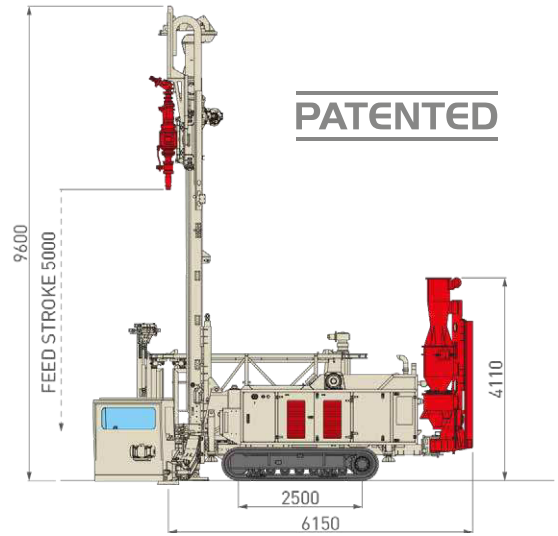
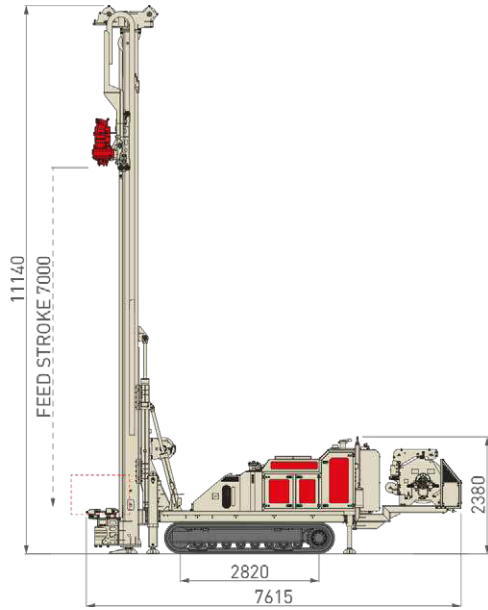
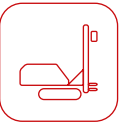

			m.s.	i.s.		
Engine Power <i>Puissance Moteur</i>	188 - 245	255 - 333	kW	HP	147 - 160	197 214
Emission Level <i>Norme d'Émissions</i>	<i>Step 3A/Tier 3 - Step 5 / Tier 4f (HT Line)</i>		-		<i>Step 3A/Tier 3 - Step 5 / Tier 4f (HT Line)</i>	
Feed Stroke <i>Course Utile</i>	4.500 - 7.000	14' 9" - 22' 12'	mm	ft-in	5.000	16' 5"
Feed Force <i>Force de Poussée</i>	12.000	26,977	daN	lbs	10.000	22,481
Retract Force <i>Force de Traction</i>	30.000	67,442	daN	lbs	20.000	44,961
Weight <i>Poids</i>	19.000 - 22.000	41,900 - 48,500	kg	lbs	19.000 - 22.000	41,900 - 48,500

	DD	RC	m.s.	i.s.	GC	RC
Rotary Torque Range <i>Couple Rotative</i>	5.365 - 13.600 3,957 - 10,031	13.600 - 27.000 10,031 - 19,914	Nm	lb*ft	13.000 9,588	13.000 9,588
Rotary Speed Range <i>Vitesse Rotative</i>	900 - 1.250	110 - 290	rpm		220 - 290	220 - 290
Clamp Range <i>Diam. Tige min/max</i>	55 - 124 2" 3/16 - 4" 7/8	45 - 360 1" 3/4 - 14" 3/16	mm	in	85 - 200 3" 3/8 - 7" 7/8	85 - 200 3" 3/8 - 7" 7/8
Fluid Circulation Pump <i>Pompe de Circulation de Fluide</i>	200 52.8	-	l/min.	gal/min.	-	-
Wire-line winch <i>Treuil Wire-line</i>	2.600 8,530	-	mm	ft	-	-





Comacchio s.r.l.

Via Callalta, 24/B - 31039 Riese Pio X (TV) (Italy)

Tel +39 0423 7585 - Fax + 39 0423 755592 - sales@comacchio.com