

## CH 3200

Up to  
**900 RPM**  
Bis zu

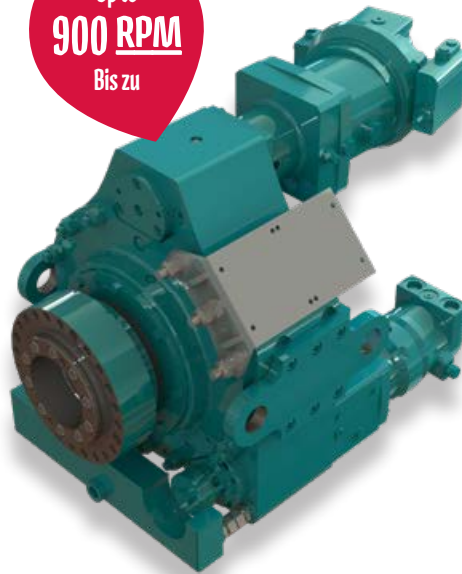

### Options Optionen

- > Hydraulic or electric shifting  
Hydraulische oder elektrische  
Schaltung
- > Mounting plates  
Montageplatten
- > Flushing head 1 1/2"  
Spülkopf 1 1/2"
- > Floating spindle  
Floating Spindel
- > Speed sensor  
Drehzahlmessung

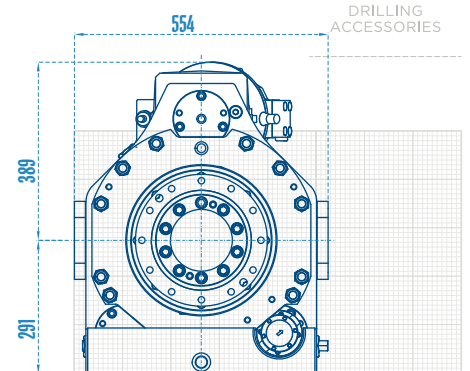
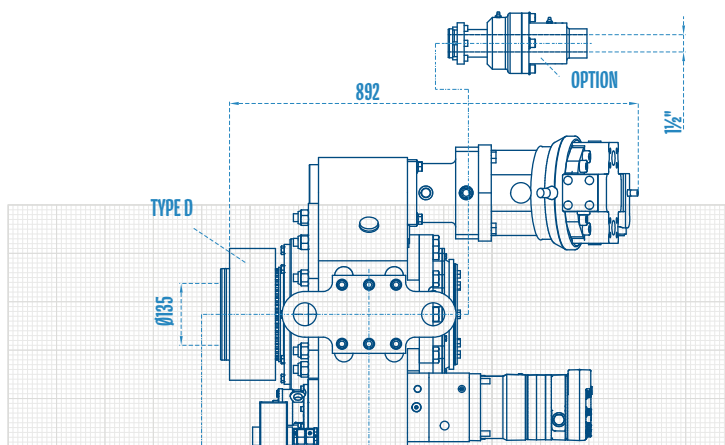

OPTION:  
FLOATING SPINDLE

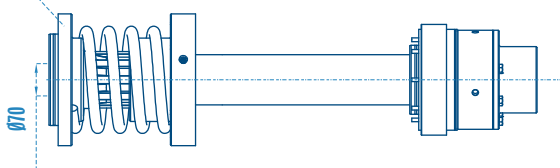

Technical Specifications are subject to modifications without prior notice and incurring responsibility for machines previously sold. The shown machines may have optional equipment. Technical data do not consider power losses. Error misprints reserved. / Technische Änderungen ohne Vorankündigung und Verpflichtung gegenüber früher gelieferten Geräten. Die abgebildeten Geräte können Sonderausstattungen haben. Technische Daten ohne Berücksichtigung des Wirkungsgrades. Irrtum und Druckfehler vorbehalten.

850 kg **Weight** Gewicht

## Rotary mechanism CH 3200 Drehantrieb

Motor Type Gear Gang	107 & 2 x HP 34				107 & 2 x HP 48				107 & 2 x HP 67			
	1	2	3	4	1	2	3	4	1	2	3	4
<b>Torque</b> Drehmoment	<b>14.17</b>	<b>9.26</b>	<b>1.91</b>	<b>1.08</b>	<b>19.02</b>	<b>12.49</b>	<b>1.91</b>	<b>1.08</b>	<b>26.04</b>	<b>17.18</b>	<b>1.91</b>	<b>1.08</b>
<b>Rotation</b> Drehzahl	<b>53</b>	<b>82</b>	<b>397</b>	<b>700</b>	<b>40</b>	<b>61</b>	<b>397</b>	<b>700</b>	<b>29</b>	<b>44</b>	<b>397</b>	<b>700</b>
p = 280 bar & Q = 170 l/min												
Motor Type Gear Gang	160 & 2 x HP 34				160 & 2 x HP 48				160 & 2 x HP 67			
	1	2	3	4	1	2	3	4	1	2	3	4
<b>Torque</b> Drehmoment	<b>15.1</b>	<b>9.9</b>	<b>2.85</b>	<b>1.69</b>	<b>20</b>	<b>13.1</b>	<b>2.85</b>	<b>1.69</b>	<b>27</b>	<b>17.8</b>	<b>2.85</b>	<b>1.69</b>
<b>Rotation</b> Drehzahl	<b>100</b>	<b>154</b>	<b>530</b>	<b>900</b>	<b>76</b>	<b>116</b>	<b>530</b>	<b>900</b>	<b>56</b>	<b>85</b>	<b>530</b>	<b>900</b>
p = 280 bar & Q = 340 l/min												

## Drive shafts Abtriebswellen

- > Flange connection  
Flanschverbindung

Other connections on request  
Weitere Verbindungen auf Anfrage

# EURODRILL

EURODRILL GMBH  
INDUSTRIESTR. 5 · 57489 DROLSHAGEN · GERMANY  
+49 2763 21228-0 · TELEFAX +49 2763 21228-22  
INFO@EURODRILL.DE · EURODRILL.DE

