

RH 200 HD 1002

available - verfügbar
Percussion unit
4.000 MIN⁻¹
Schlagfrequenz

Options Optionen

- > Hydraulic, electric or manual shifting
Hydraulische, elektrische oder manuelle Schaltung
- > Mounting plates
Montageplatten
- > Flushing head 1"
Spülkopf 1"
- > Shock Absorber
- > Floating spindle
Floating Spindel
- > Percussion unit type 10
Schlagwerk Typ 10

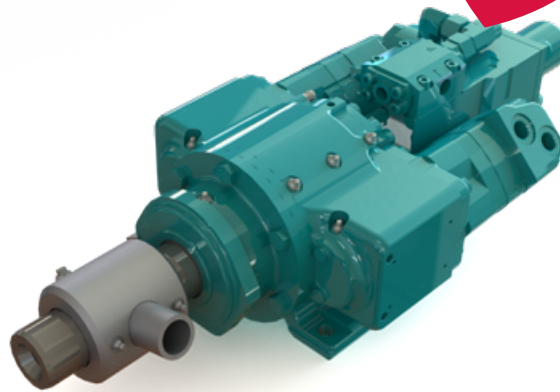

HD 1002

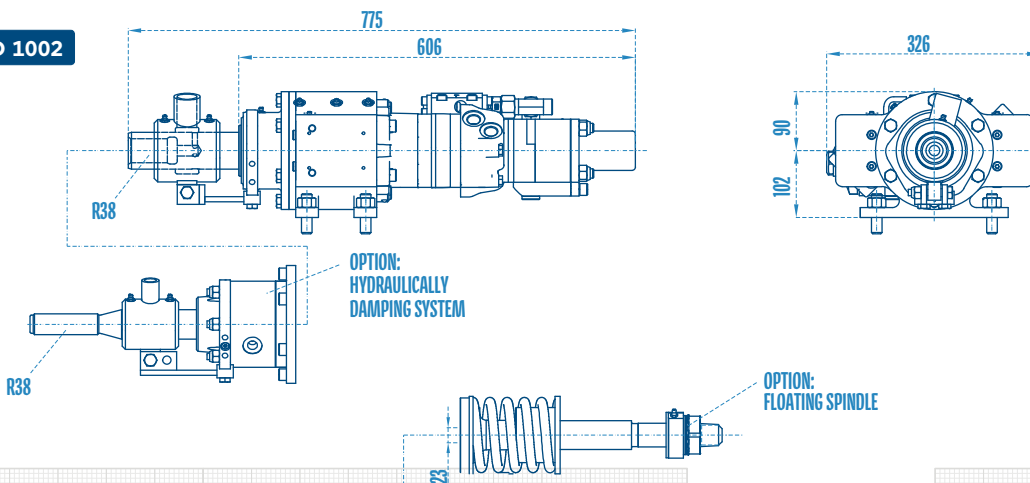

RH 200

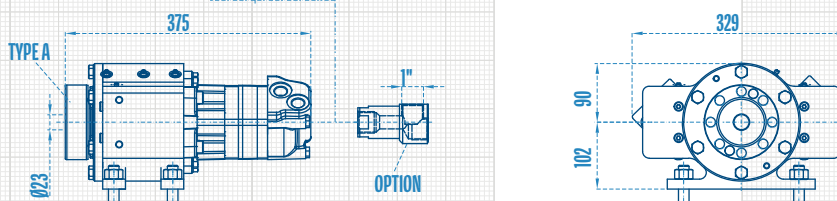

Technical Specifications are subject to modifications without prior notice and incurring responsibility for machines previously sold. The shown machines may have optional equipment. Technical data do not consider power losses. Error misprints reserved. / Technische Änderungen ohne Vorankündigung und Verpflichtung gegenüber früher gelieferten Geräten. Die abgebildeten Geräte können Sonderausstattungen haben. Technische Daten ohne Berücksichtigung des Wirkungsgrades. Irrtum und Druckfehler vorbehalten.



65 - 95 kg **Weight** Gewicht · 35/60 kN **Traction** Zugkraft

Rotary mechanism RH 200 / HD 1002 Drehantrieb

Motor Type Motor Typ Gang Gang	84		85		86		87		88	
	1	2	1	2	1	2	1	2	1	2
Torque Drehmoment	880	440	1080	540	1420	710	1740	860	2120	1060
Rotation Drehzahl	182	364	146	292	112	224	92	184	75	150

p = 200 bar & Q = 50 l/min

Percussion unit Schlagwerk

Type Typ	HD 1002	RD 1002
	STANDARD	HIGH FREQUENCY
Operating pressure Arbeitsdruck	140 - 180	140 - 180
Oil capacity Ölmenge	25 - 40	45 - 55
Single blow energy Einzelschlagenergie	... 180	... 180
No. of blows Schlagfrequenz	... 3000	... 4000

Drive shafts Abtriebswellen

- > Flange connection
Flanschverbindung
- > API 2 3/8" Reg Box

Other connections on request
Weitere Verbindungen auf Anfrage

Shank adapters Einsteckenden

- > R44 LH / RH & IB30, IB40 & IB52
- > R32, R38, T38 & T45

Other shank adapters on request
Weitere Einsteckenden auf Anfrage